

Mostostal

Grupa Mostostal Warszawa

P U Ł A W Y



USŁUGI DŻWIGOWE
STOCK OF LIFTING EQUIPMENT

USŁUGI DŹWIGOWE STOCK OF LIFTING EQUIPMENT

Mostostal Puławy S.A. świadczy specjalistyczne usługi dźwigowe. Udźwig sprzętu dźwigowego w zakresie od 10t do 100t. Firma dysponuje najnowocześniejszym sprzętem, renomowanych producentów:

- Żurawie samochodowe – udźwig od 10 do 100t
- Żurawie terenowe – udźwig od 45t
- Żurawie wieżowe – udźwig do 120Tm
- Podnośniki koszowe – wysokość robocza do 40m
- Podnośniki teleskopowe

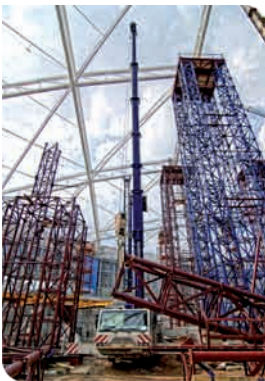

Mostostal Puławy S.A. provides specialised lifting services. Lifting capacity of the lifting equipment ranges from 10 to 100 tonnes. The company owns the most modern equipment from reputable manufacturers:

- Mobile cranes - lifting capacity from 10 to 100 tonnes
- Rough terrain cranes – lifting capacity from 45 tonnes
- Tower cranes - lifting capacity to 120 Tm
- Man lifts – working height up to 40m
- Telescopic lifts





s. 4-5

**ŻURAW SAMOJEZDNY
TEREX DEMAG AC 100/4**



s. 7-6

**ŻURAW SAMOJEZDNY
TEREX DEMAG AC 80-2**



s. 8-9

**ŻURAW SAMOJEZDNY
TEREX DEMAG AC 60/3L**



s. 10-11

**ŻURAW SAMOJEZDNY
TEREX DEMAG AC 55-1**



s. 12-13

**ŻURAW SAMOJEZDNY
TEREX DEMAG AC 40/2L**



s. 14-15

**ŻURAW WOLNOBIEŻNY
TERENOWY
TEREX A450**



s. 16-17

**ŻURAW SAMOJEZDNY
HYDROS T321**



s. 18

**PODNOŚNIK TELESKOPOWY
Manitou MRT 2150**



**PODNOŚNIK TELESKOPOWY
Manitou MT 1440**



s. 19



s. 20

**PODNOŚNIK
TELESKOPOWY
HT 285**



s. 21

**PODNOŚNIK KOSZOWY
NISSAN GT 21-10**



s. 22

**PODNOŚNIK KOSZOWY
GENIE S-125**



s. 23

**PODNOŚNIK
KOSZOWY
TZ50**

USŁUGI DŹWIGOWE

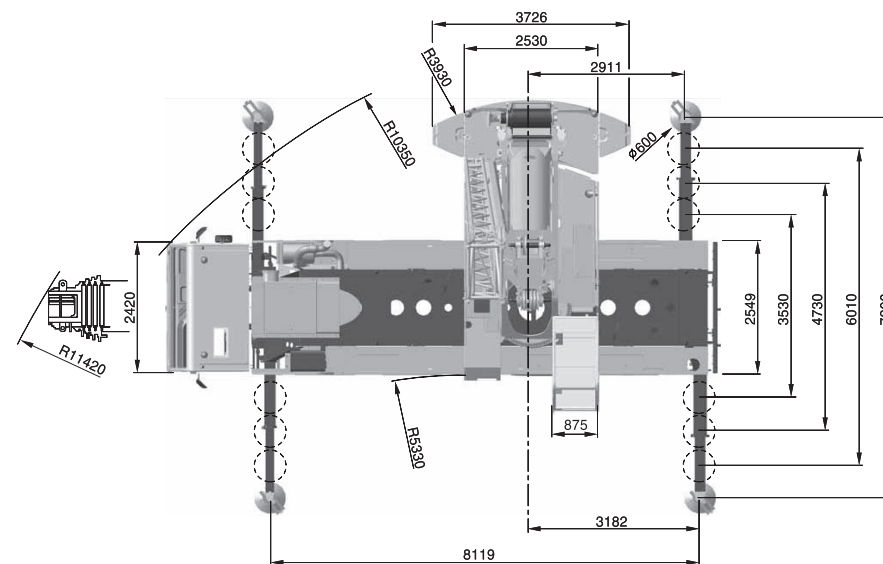
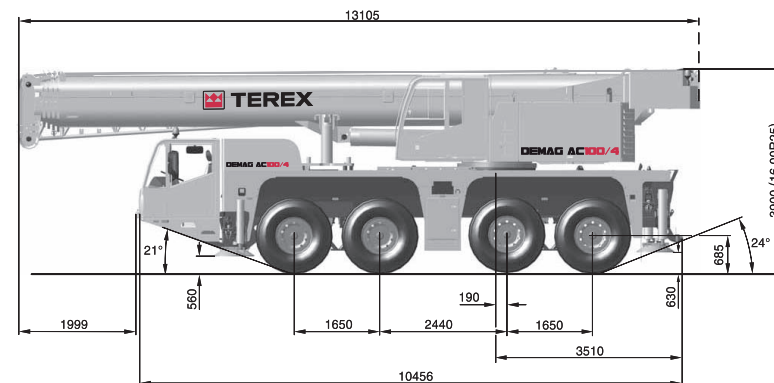

ŻURAW SAMOJEZDNY TEREX DEMAG AC 100/4

udźwig 100t
wysięg 50m + 19m

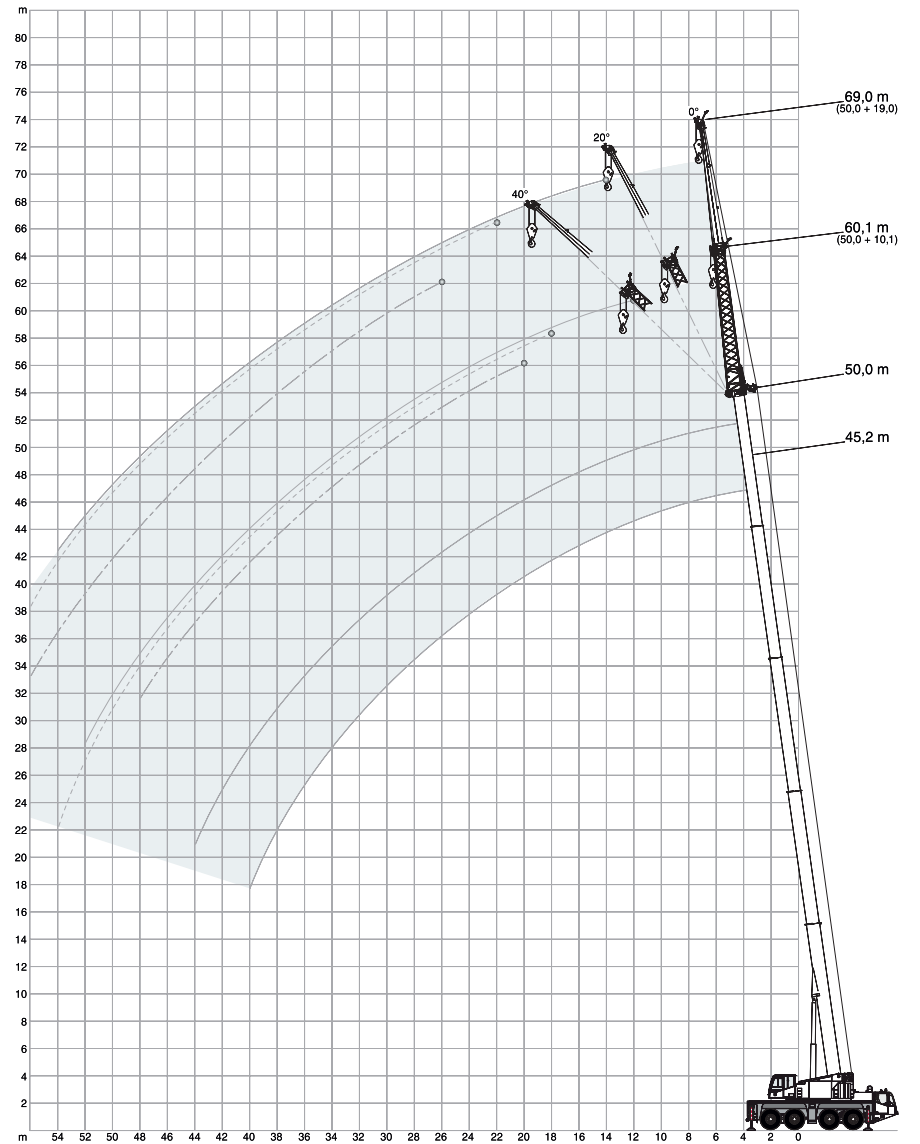
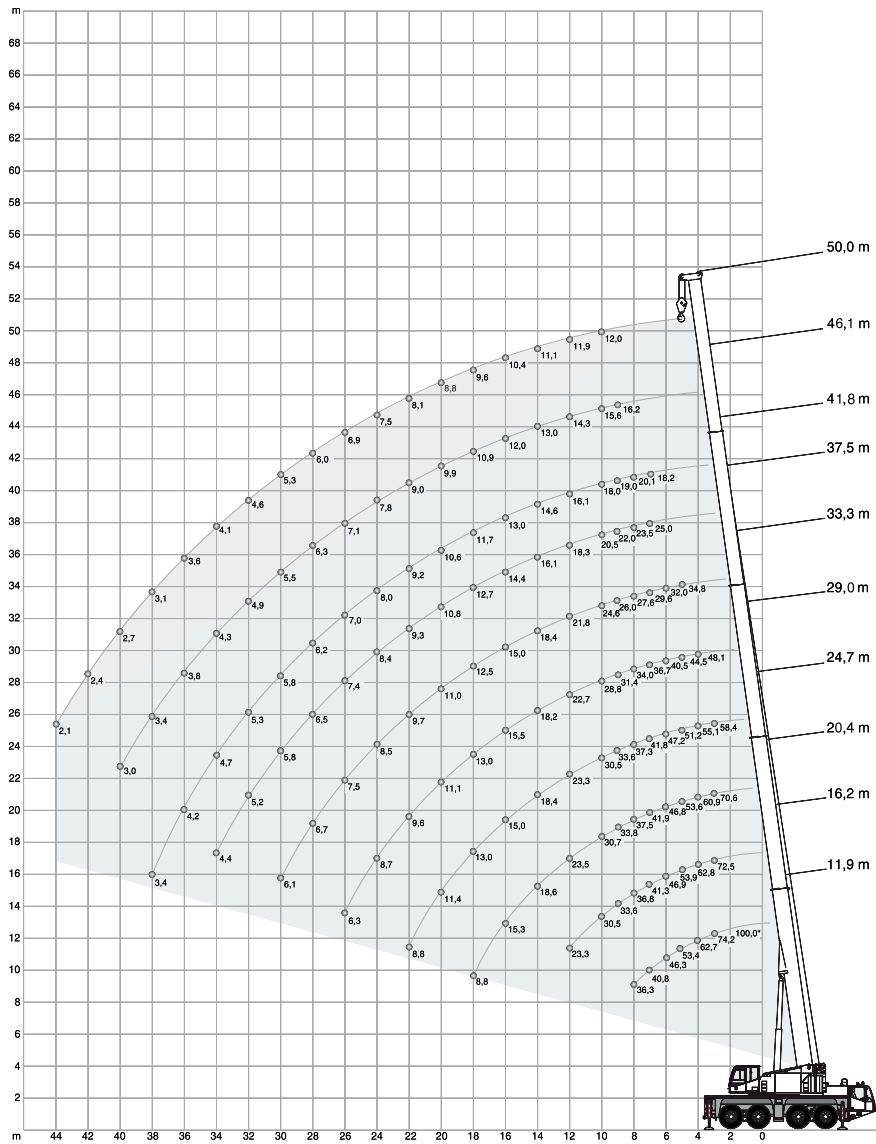

TEREX DEMAG AC 100/4

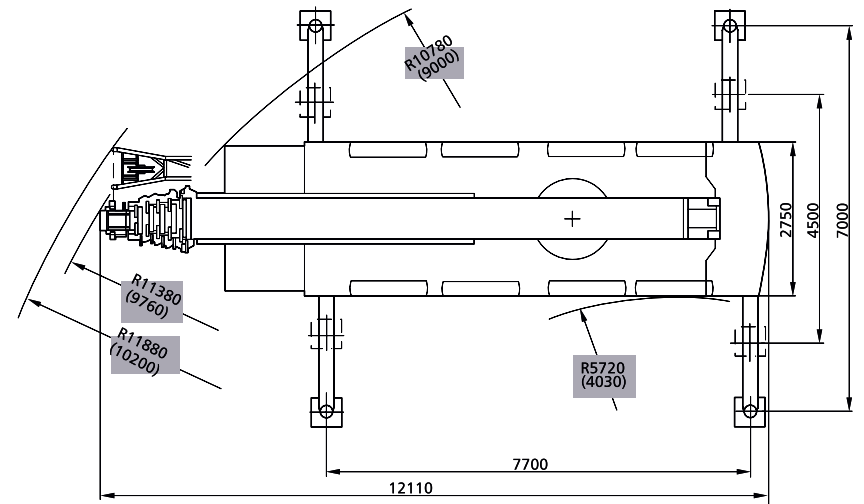
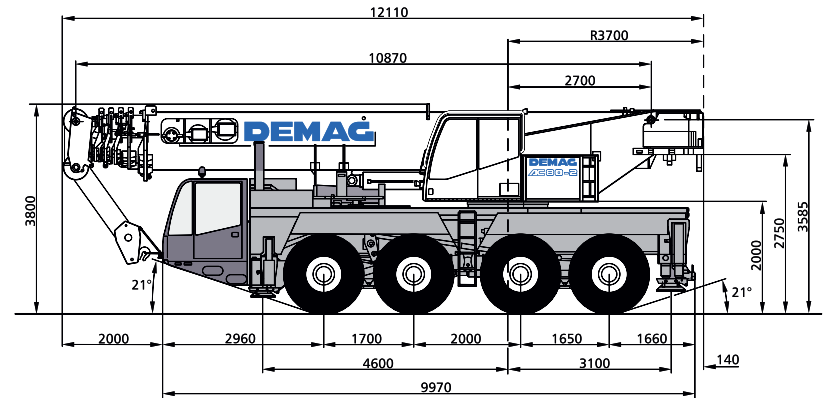

**ŻURAW SAMOJEZDNY
TEREX DEMAG AC 80-2**

**udźwig 80t
wysięg 50m + 17,6m**

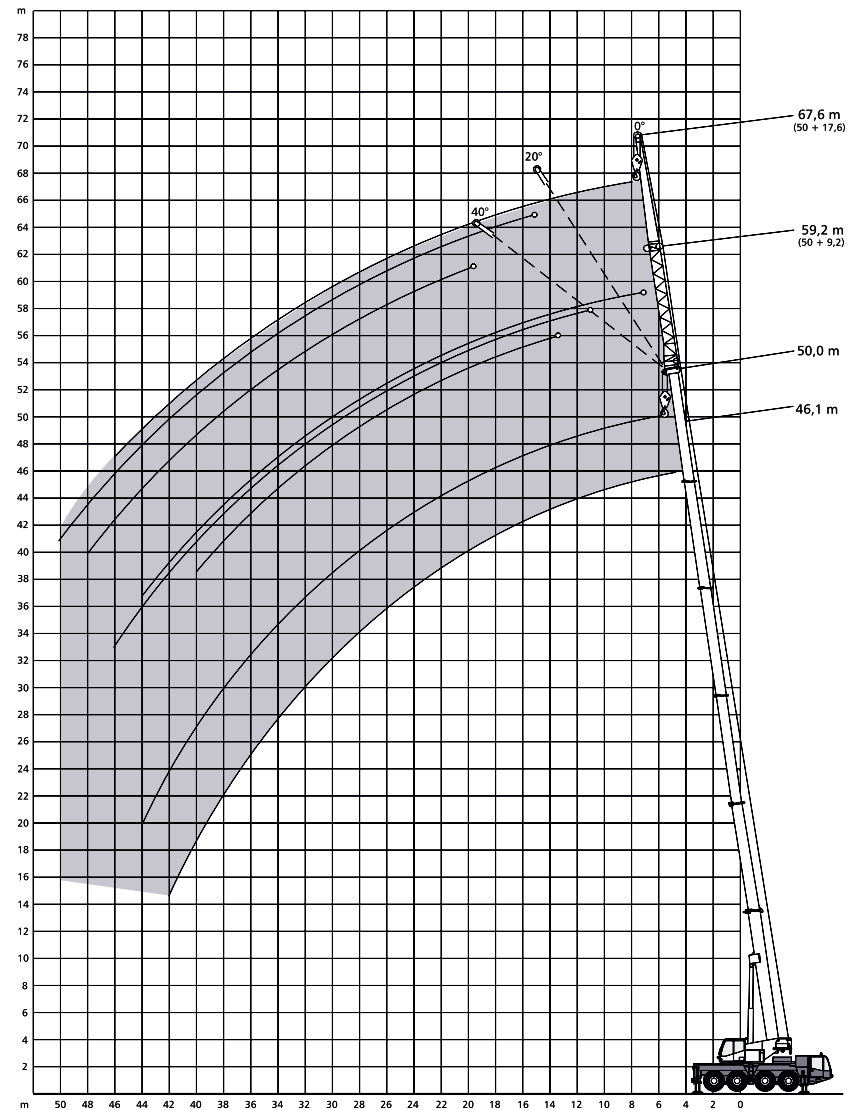
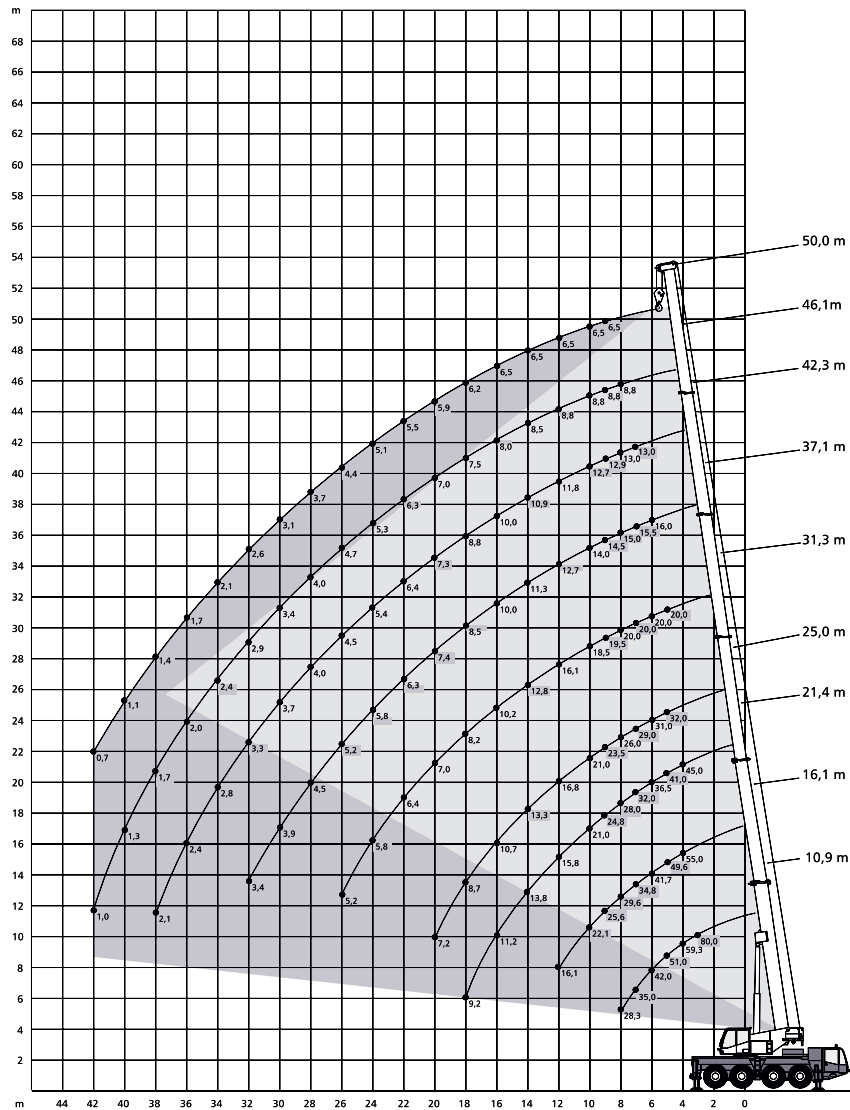

TEREX DEMAG AC 80-2

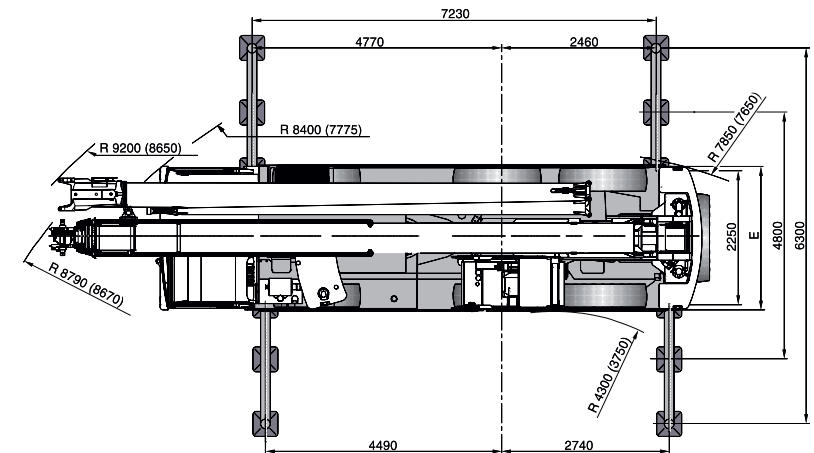
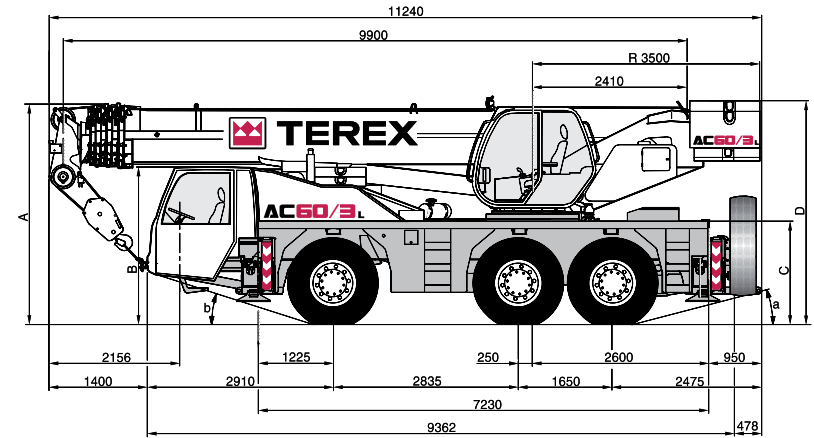

**ŻURAW SAMOJEZDNY
TEREX DEMAG AC 60/3L**

**udźwig 60t
wysięg 44m + 15,35m**

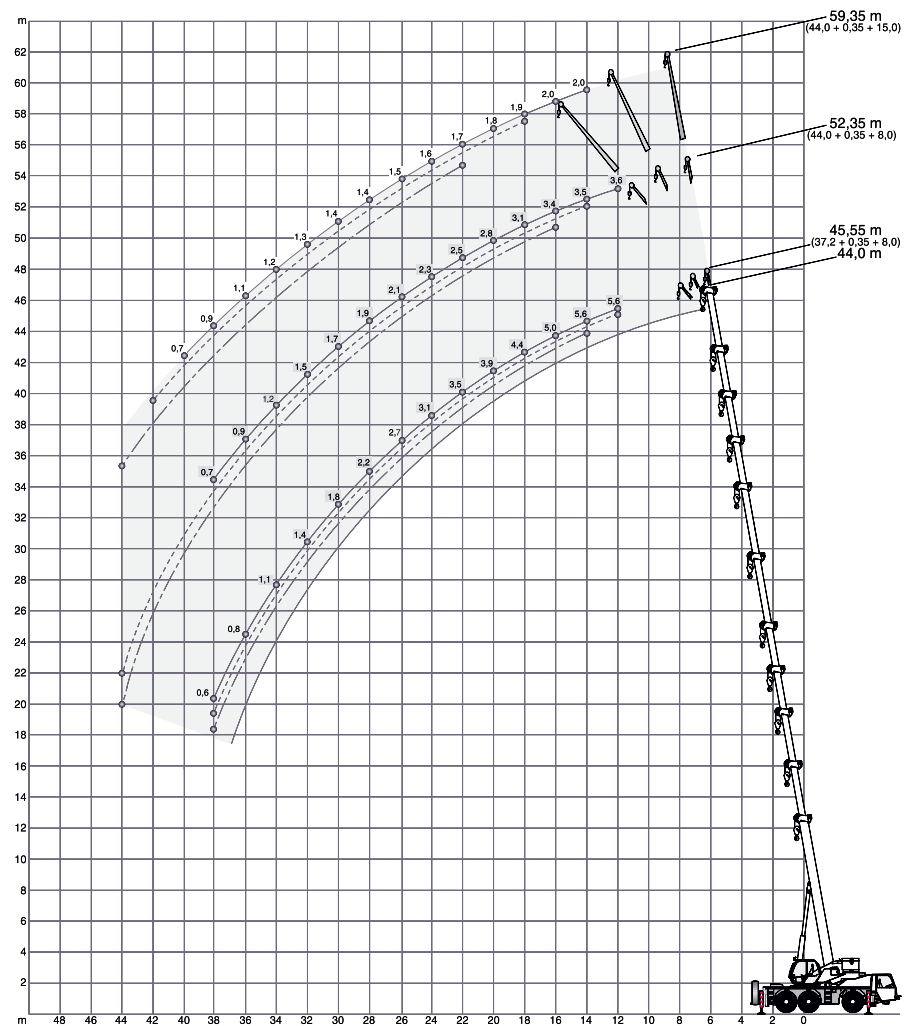
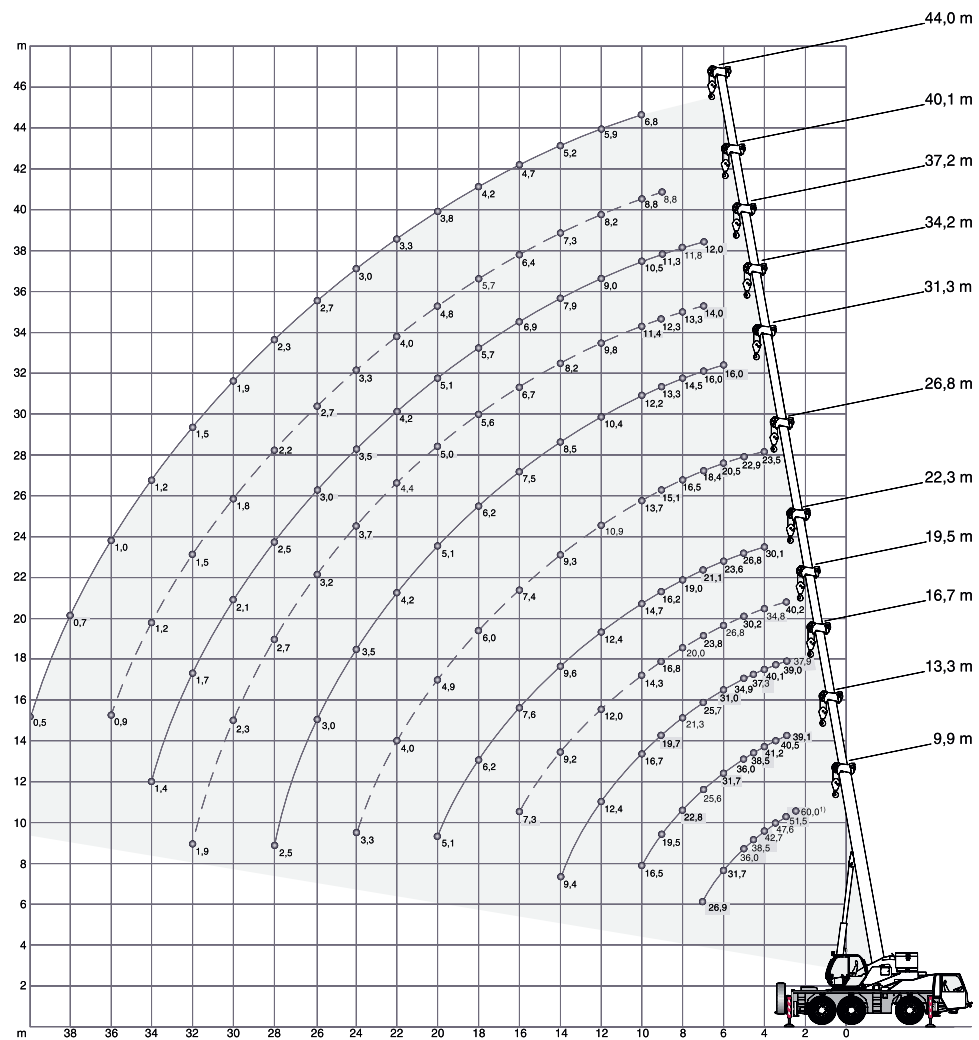

TEREX DEMAG AC 60/3L

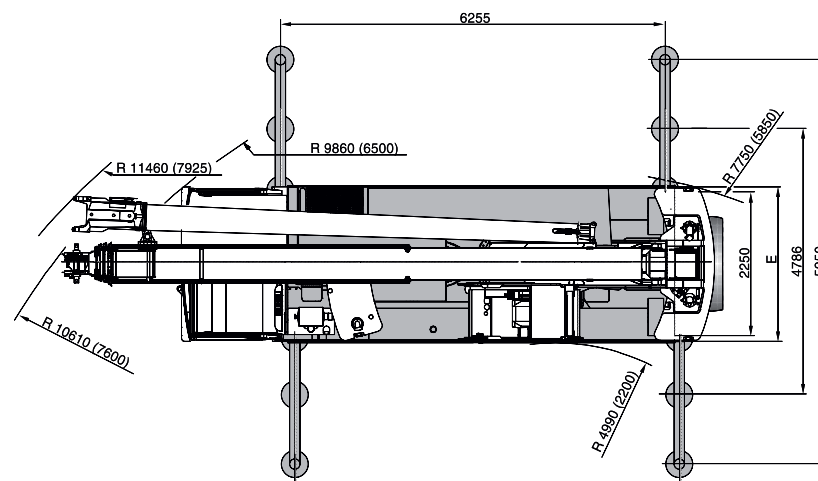
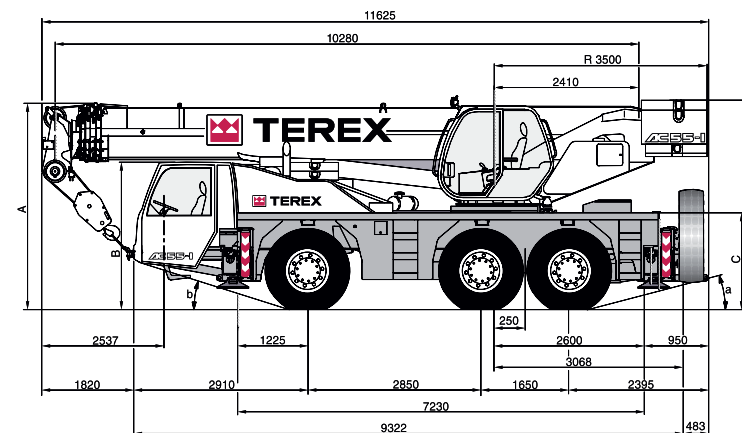
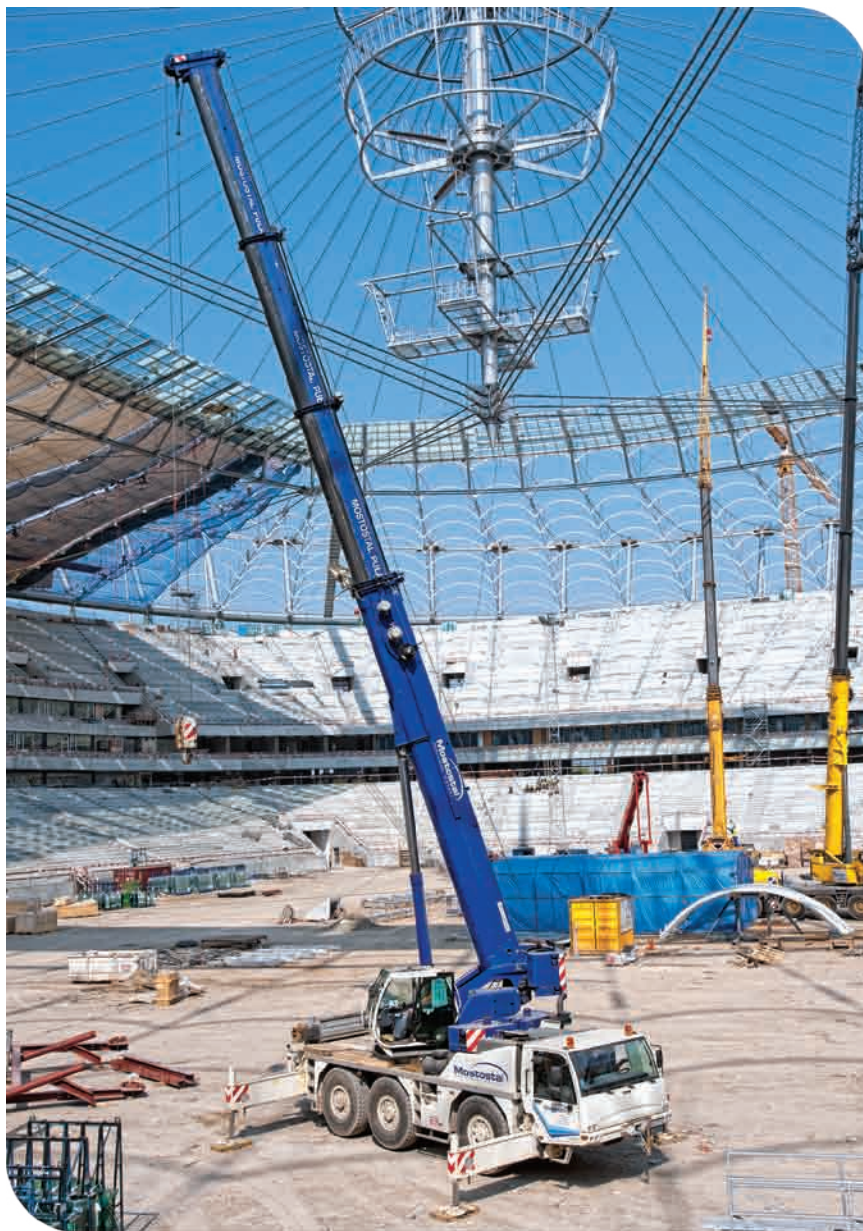

ŻURAW SAMOJEZDNY TEREX DEMAG AC 55-1

udźwig 55t
wysięg 40m + 15,35m

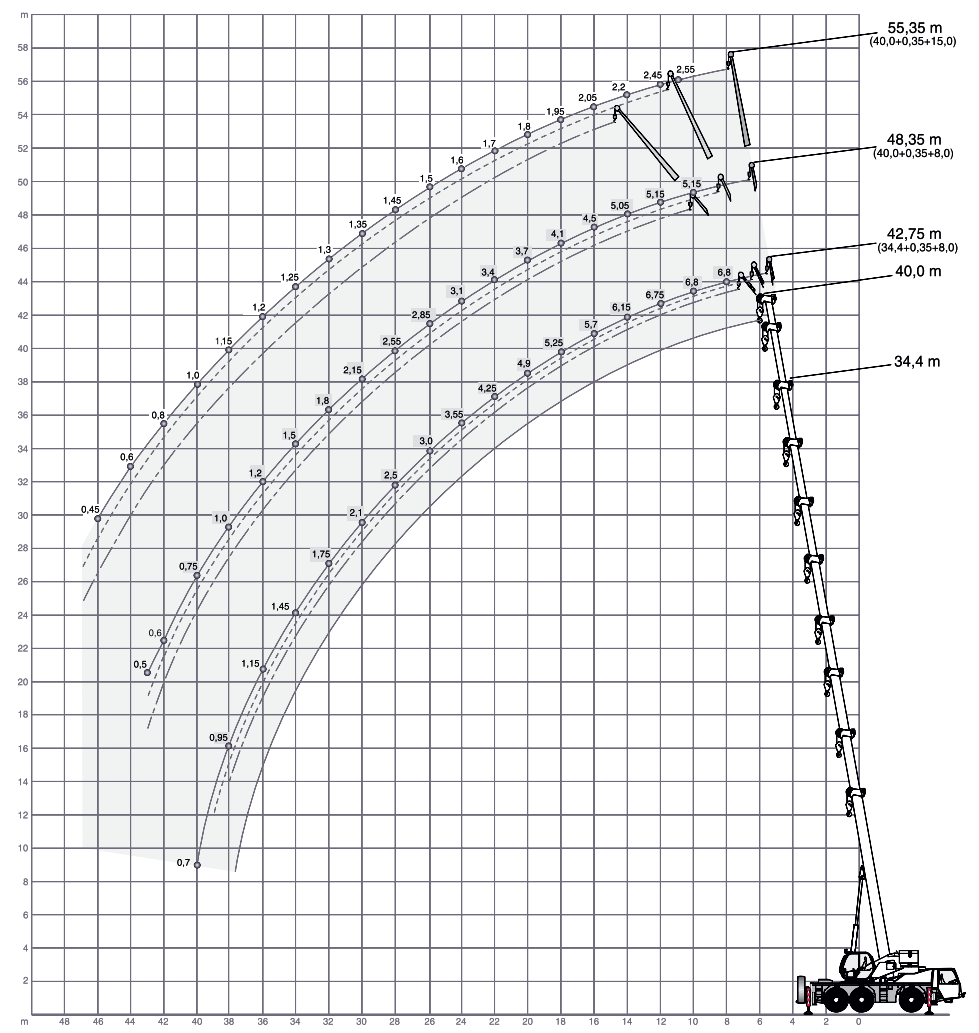
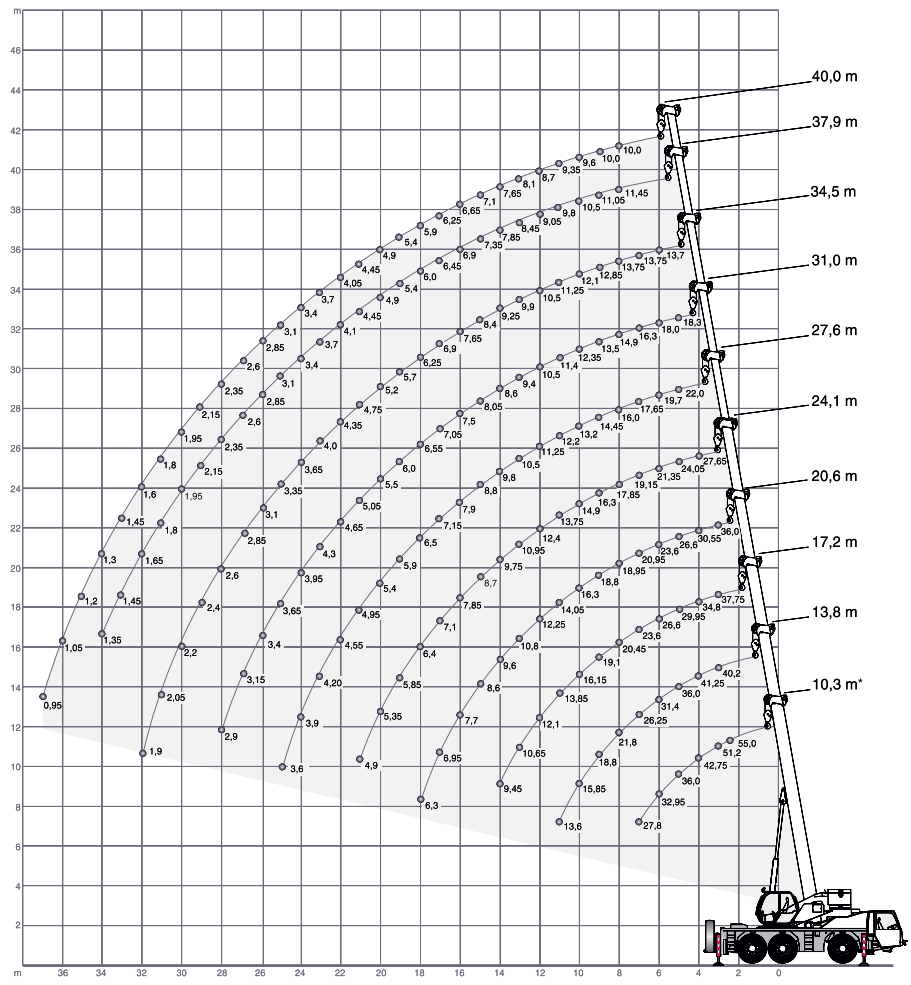

TEREX DEMAG AC 55-1

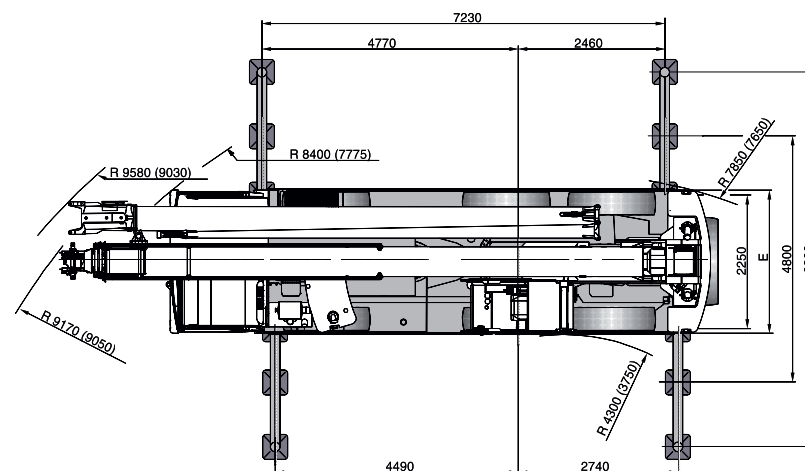
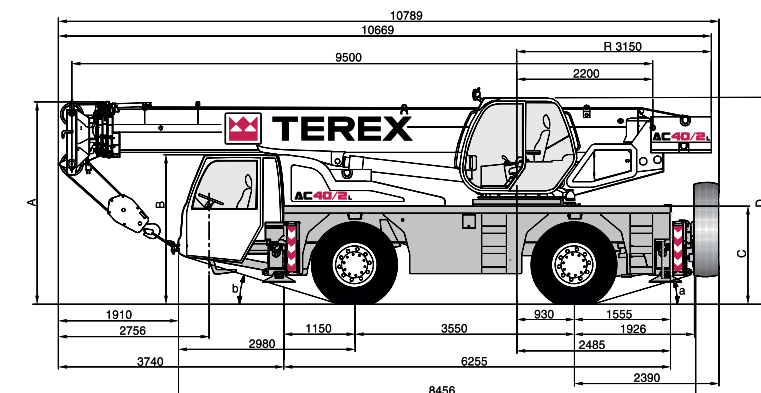

**ŻURAW SAMOJEZDNY
TEREX DEMAG AC 40/2L**

**udźwig 40t
wysięg 37,4m**

5,5 t 6,20 m x 5,95 m 360° DIN/ISO

Radius · Ausladung											Radius · Ausladung	
Portée											Portée	
Sbraccio											Sbraccio	
Main boom · Hauptausleger · Flèche principale · Braccio base · Pluma principal												
Radio	m	9,50 ¹⁾	9,50	13,00	16,50	19,80	23,50	26,80	30,50	34,10	37,40	Radio
m	t	t	t	t	t	t	t	t	t	t	t	m
2,6	40,00	-	-	-	-	-	-	-	-	-	-	2,6
3	35,00	32,00	31,20	25,95	18,95	-	-	-	-	-	-	3
3,5	30,15	27,45	27,45	23,70	18,35	18,40	-	-	-	-	-	3,5
4	27,75	24,90	24,90	22,00	18,60	17,55	-	-	-	-	-	4
4,5	25,00	22,60	22,60	20,45	17,95	16,25	14,45	-	-	-	-	4,5
5	22,30	20,60	20,60	19,05	16,75	15,15	13,85	-	-	-	-	5
6	17,80	17,00	17,00	17,00	14,70	13,30	12,20	10,00	-	-	-	6
7	14,45	14,45	14,50	14,50	12,75	11,80	10,90	9,65	7,45	-	-	7
8	-	-	11,50	11,50	11,50	10,20	9,75	8,80	7,45	5,55	-	8
9	-	-	9,50	9,50	9,50	8,70	8,55	8,00	7,05	5,35	-	9
10	-	-	8,00	8,00	8,00	7,50	7,40	7,30	6,70	5,00	-	10
11	-	-	-	6,70	6,70	6,70	6,50	6,40	6,15	4,65	-	11
12	-	-	-	6,00	6,00	6,00	6,00	5,70	5,60	4,40	-	12
13	-	-	-	5,20	5,20	5,20	5,20	5,05	5,00	4,15	-	13
14	-	-	-	4,60	4,60	4,60	4,60	4,50	4,50	3,95	-	14
15	-	-	-	-	4,00	4,00	4,00	4,00	4,00	3,70	-	15
16	-	-	-	-	3,60	3,60	3,60	3,55	3,60	3,45	-	16
17	-	-	-	-	3,20	3,20	3,20	3,15	3,20	3,20	-	17
18	-	-	-	-	-	2,80	2,80	2,80	2,80	2,80	-	18
19	-	-	-	-	-	2,60	2,60	2,50	2,60	2,60	-	19
20	-	-	-	-	-	2,50	2,50	2,25	2,35	2,40	-	20
21	-	-	-	-	-	2,30	2,30	2,00	2,25	2,15	-	21
22	-	-	-	-	-	2,00	2,00	1,80	2,00	1,95	-	22
23	-	-	-	-	-	1,80	1,60	1,80	1,75	1,75	-	23
24	-	-	-	-	-	1,70	1,45	1,70	1,60	1,60	-	24
25	-	-	-	-	-	-	1,35	1,50	1,45	1,45	-	25
26	-	-	-	-	-	-	1,25	1,40	1,30	1,30	-	26
27	-	-	-	-	-	-	1,15	1,30	1,15	1,15	-	27
28	-	-	-	-	-	-	1,05	1,20	1,05	1,05	-	28
29	-	-	-	-	-	-	-	1,10	0,90	0,90	-	29
30	-	-	-	-	-	-	-	-	1,00	0,80	-	30
31	-	-	-	-	-	-	-	-	0,90	0,70	-	31
32	-	-	-	-	-	-	-	-	-	0,60	-	32

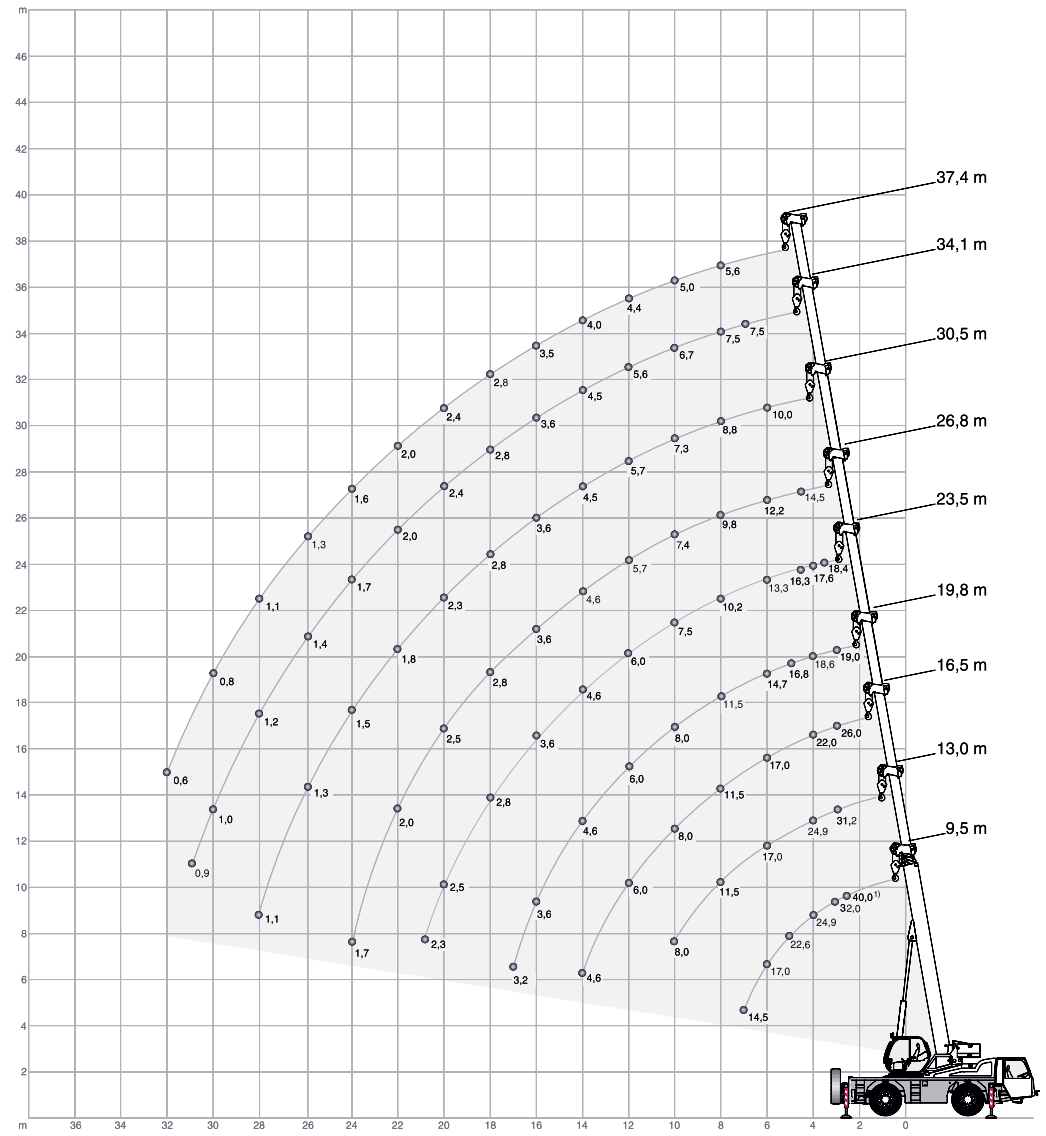

TEREX DEMAG AC 40/2L

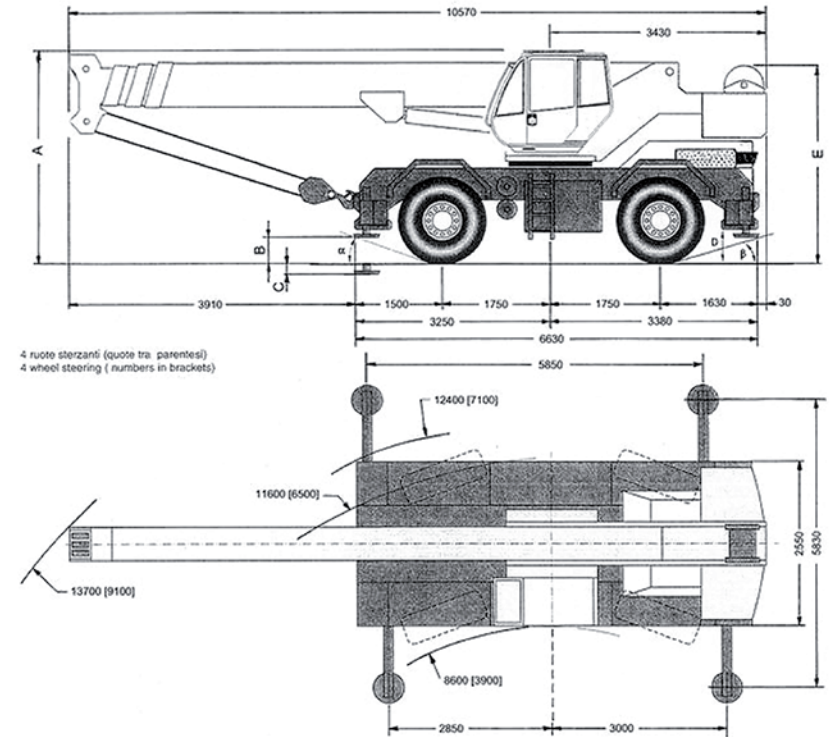

ŻURAW WOLNOBIEŻNY TERENOWY TEREX A450

udźwig 40t
wysięg 30m + 8m

TEREX A450

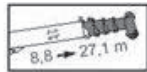
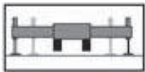

	BRACCIO PRINCIPALE / MAIN BOOM HAUPTAUSLEGER / FLECHE PRINCIPALE							
	8,80 m	11,80 m	14,90 m	18,00 m	21,00 m	24,10 m	27,10 m	
	DIN	DIN	DIN	DIN	DIN	DIN	DIN	
3	40,00	29,00	26,10					3
4	28,40	26,80	24,30	19,20				4
5	21,60	21,60	20,20	16,40	15,20	13,50		5
6	17,50	17,50	17,00	14,30	13,30	12,00	10,60	6
7	14,60	14,60	14,40	12,70	11,80	10,70	9,50	7
8		12,00	11,90	11,30	10,50	9,60	8,50	8
9		9,40	9,60	9,60	9,60	8,70	7,70	9
10			7,90	7,90	7,90	8,00	7,00	10
12			5,60	5,70	5,70	5,80	5,70	12
14				4,30	4,30	4,40	4,50	14
16					3,30	3,40	3,50	16
18					2,60	2,70	2,80	18
20						2,10	2,20	20
22							2,00	22
24							1,80	24
26								26
28								28

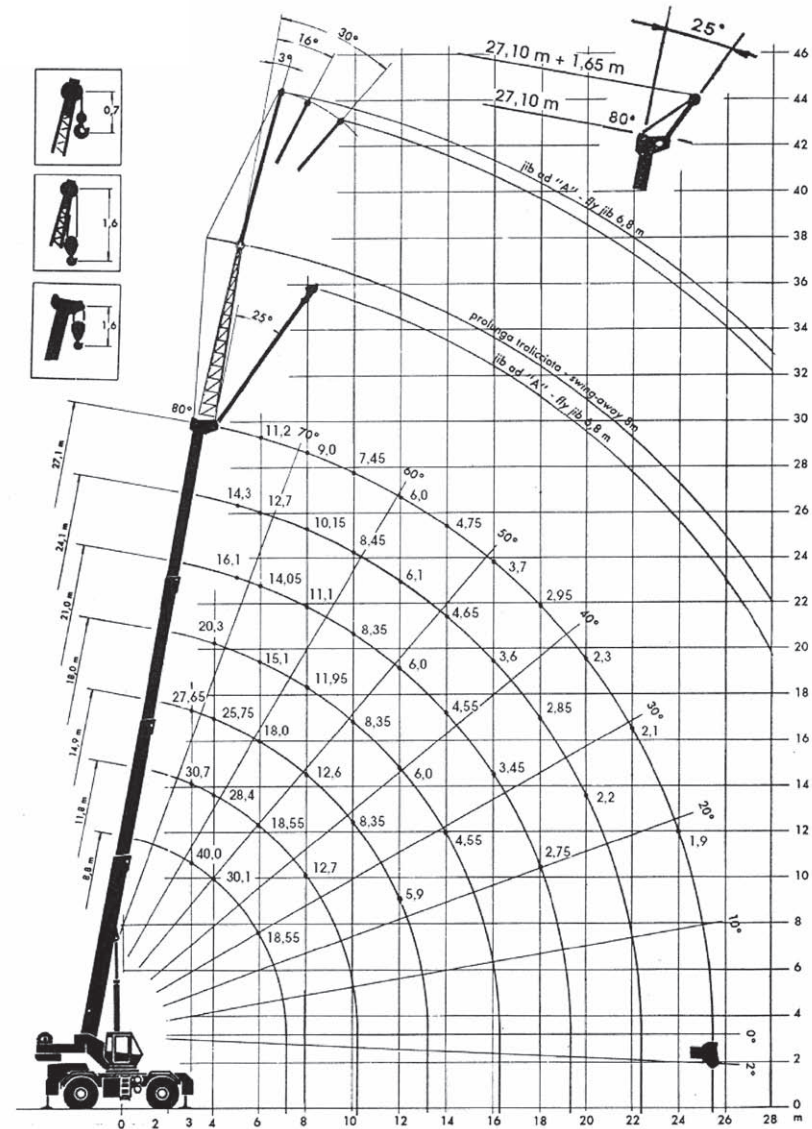

**ŻURAW SAMOJEZDNY
HYDROS T321**
udźwig 32t
wysięg 34m + 7m

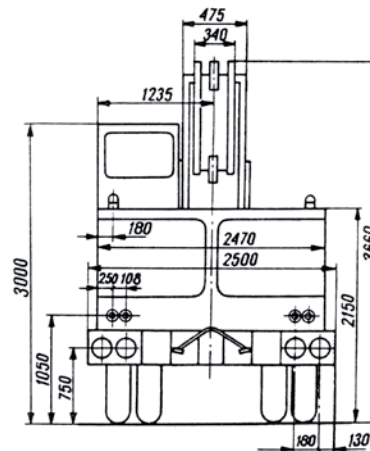
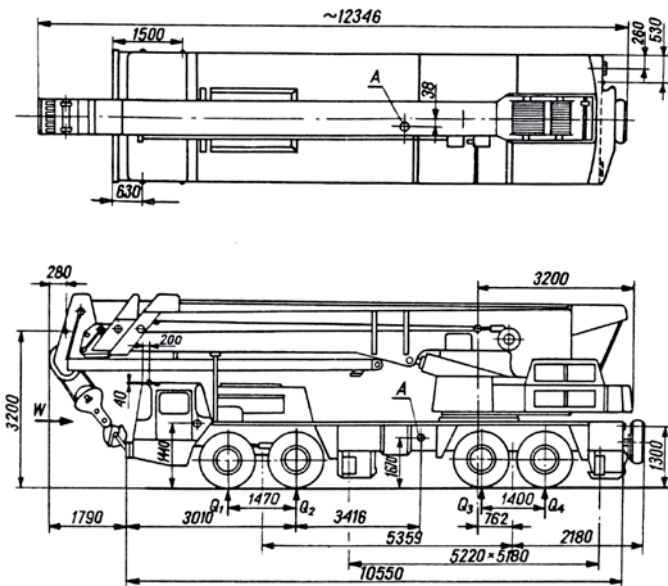

Wysięg [m]	Wysięgnik główny oraz 4-ta sekcja												
	Długość wysięgnika a głównego bez 4-tej sekcji wysuniętej												
	10,67 do 12,2	12,2 do 15,25	15,25 do 18,30	18,30 do 21,35	21,35 do 23,76	23,76 do 25,00	10,67 do 25,0 + 7,16						
	Tył	Tył	Bok	Tył	Bok	Tył	Bok	Tył	Bok	Tył	Bok	Tył	kąt
3,0	32 000	27 000											
3,5	27 000	24 500	23 000	23 000									
4,5	21 000	20 500	19 000	19 000	16 150	16 150							
6,0	15 400	15 400	15 400	15 400	13 850	13 850	10 300	10 300	8 750	8 750			
7,5		11 250	11 250	12 430	10 720	10 720	8 250	8 250	7 220	7 220	4 380	4 380	77
9,0		7 700	7 800	10 100	7 750	7 750	7 320	7 320	6 180	6 180	4 120	4 120	74
10,5		5 770	5 960	7 700	5 890	7 000	5 870	6 420	5 680	5 680	3 870	3 870	71
12,0			4 520	6 120	4 520	5 790	4 520	5 630	4 520	4 910	3 580	3 580	68
15,0					2 840	4 030	2 840	4 030	2 840	3 980	2 990	2 990	62
18,0							1 830	2 750	1 830	2 750	2 165	2 215	55
21,0									1 150	1 830	1 490	1 540	48
24,0											1 030	1 135	40

Uwaga! Od podanego udźwigu należy odjąć ciężar zblacza i zawiesi. Do żurawia stosuje się zblacza

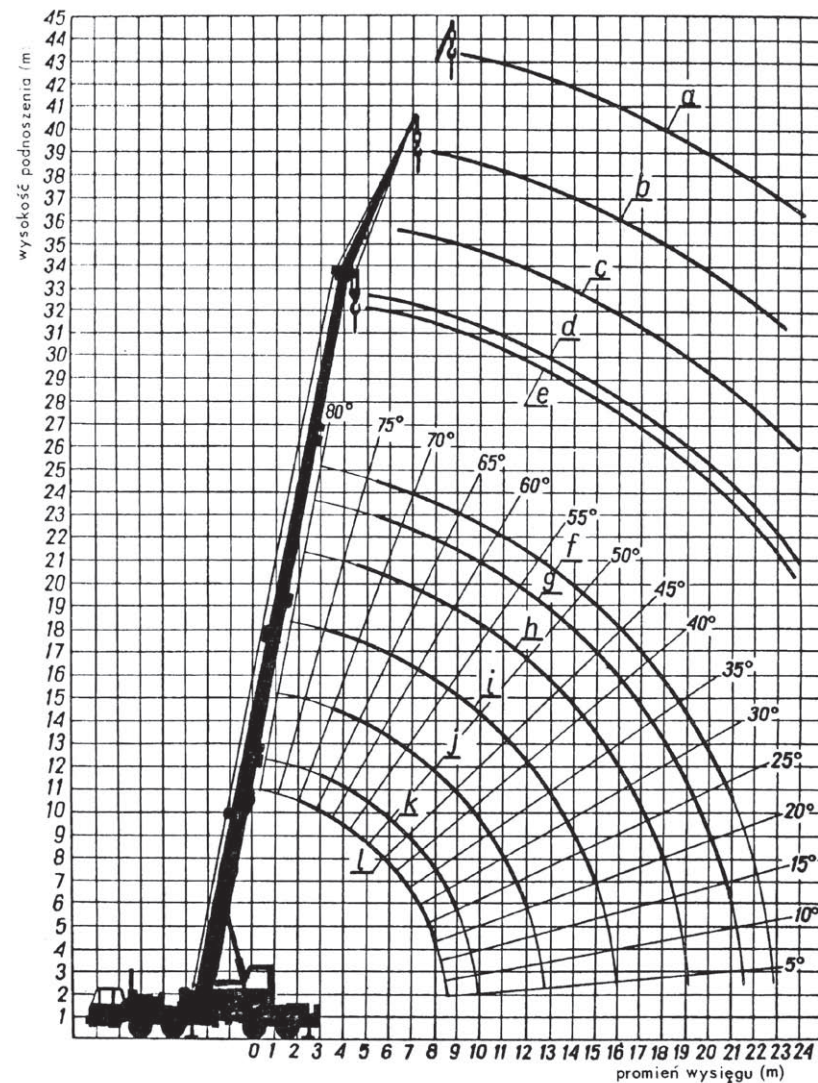

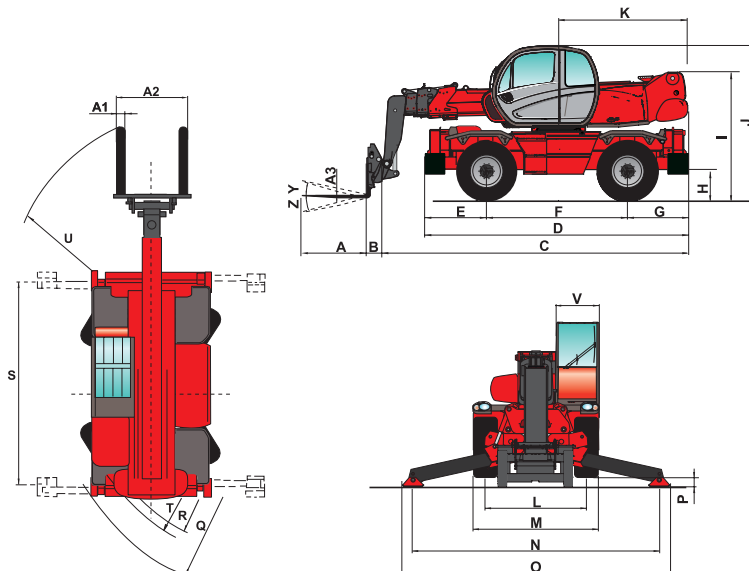
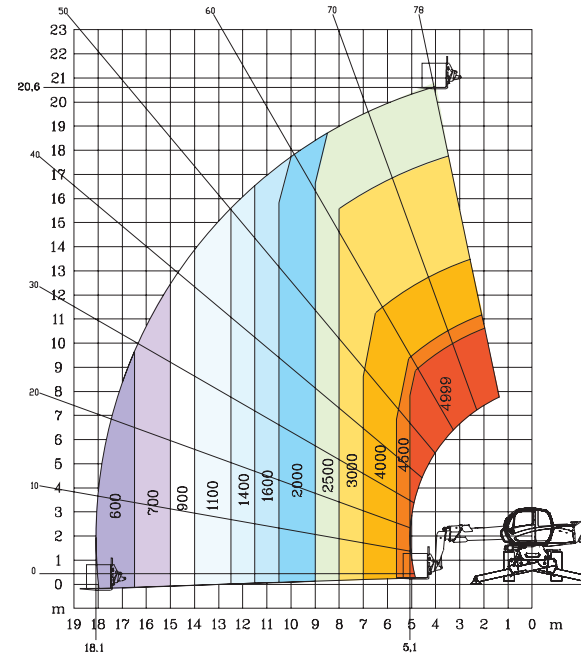

PODNOŚNIK TELESKOPOWY
Manitou MRT 2150
 udźwig 5t
 wysięg 21m (z przedłużką koszową 27m)

MANITOU MRT 2150

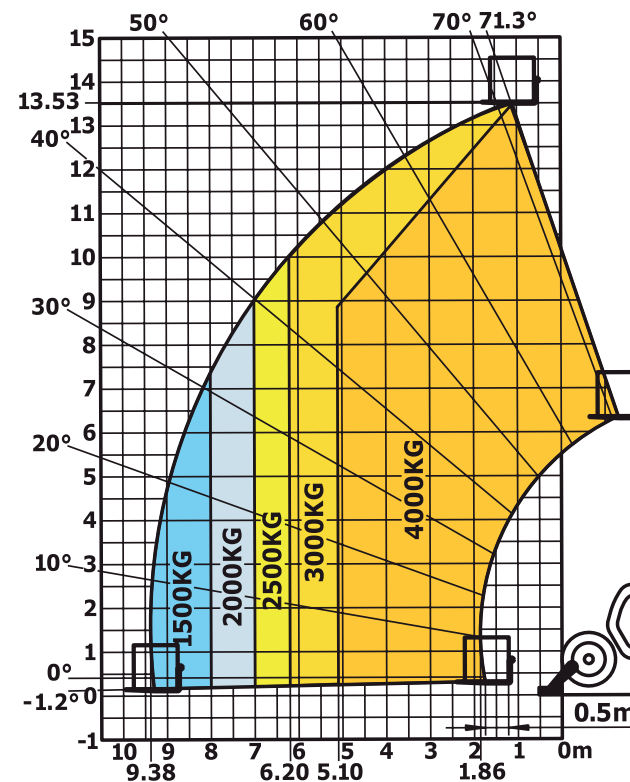
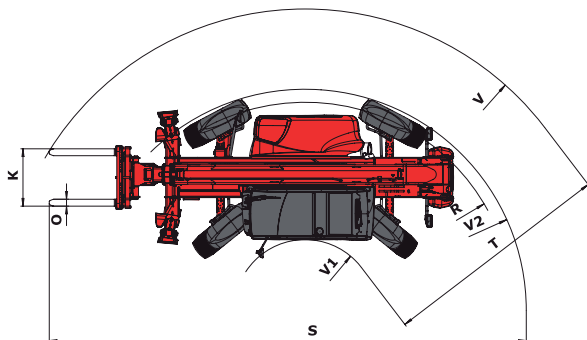
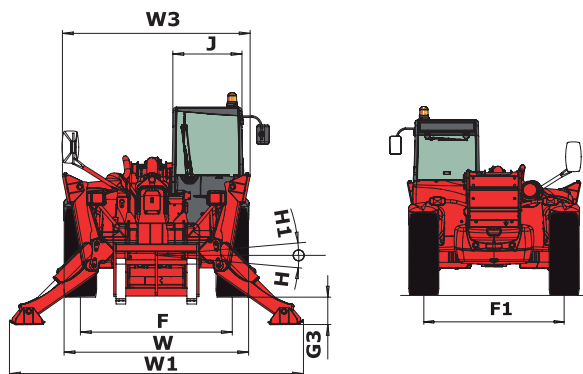
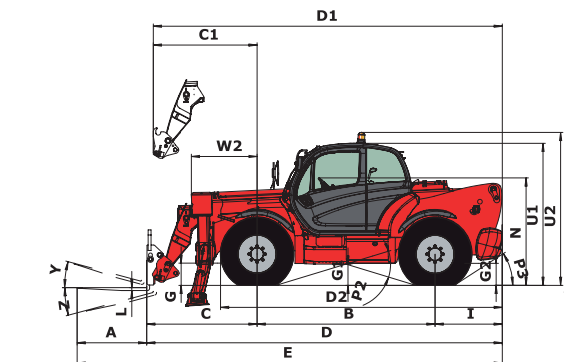

PODNOŚNIK TELESKOPOWY
Manitou MT 1440
 udźwig 4t wsięgię 14m

MANITOU MT 1440

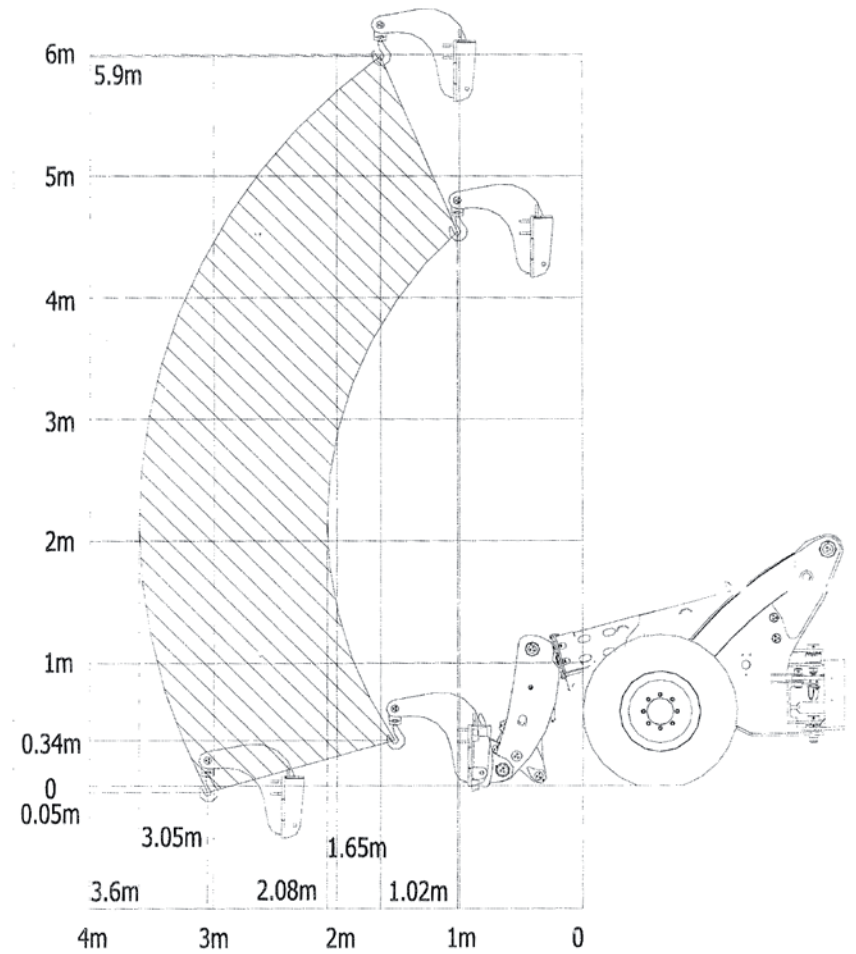

PODNOŚNIK TELESKOPOWY HT 285
udźwig 2,8t wysięg 6m

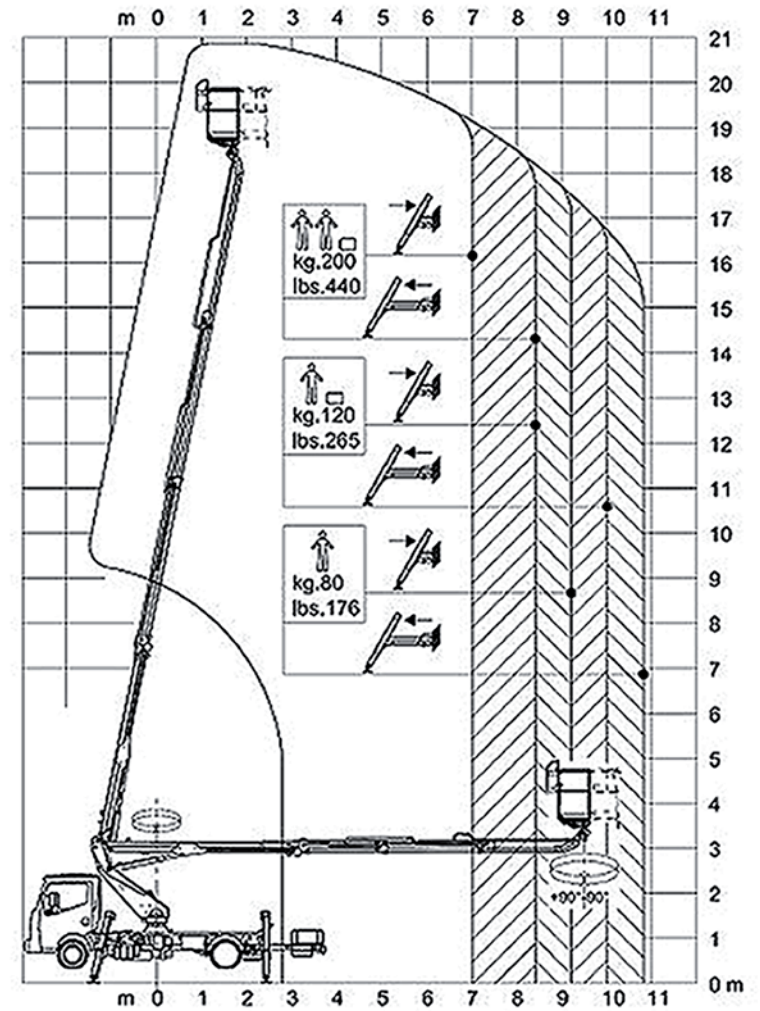
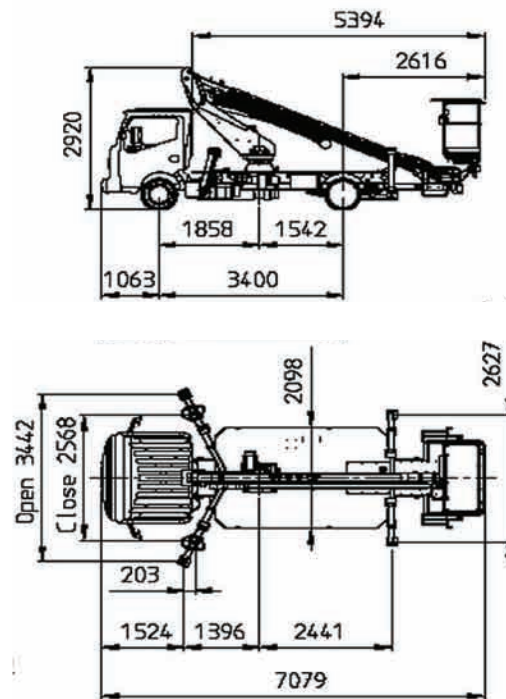

PODNOŚNIK KOSZOWY NISSAN GT 21-10
 udźwig 200kg wysokość robocza 21m

NISSAN GT 21-10

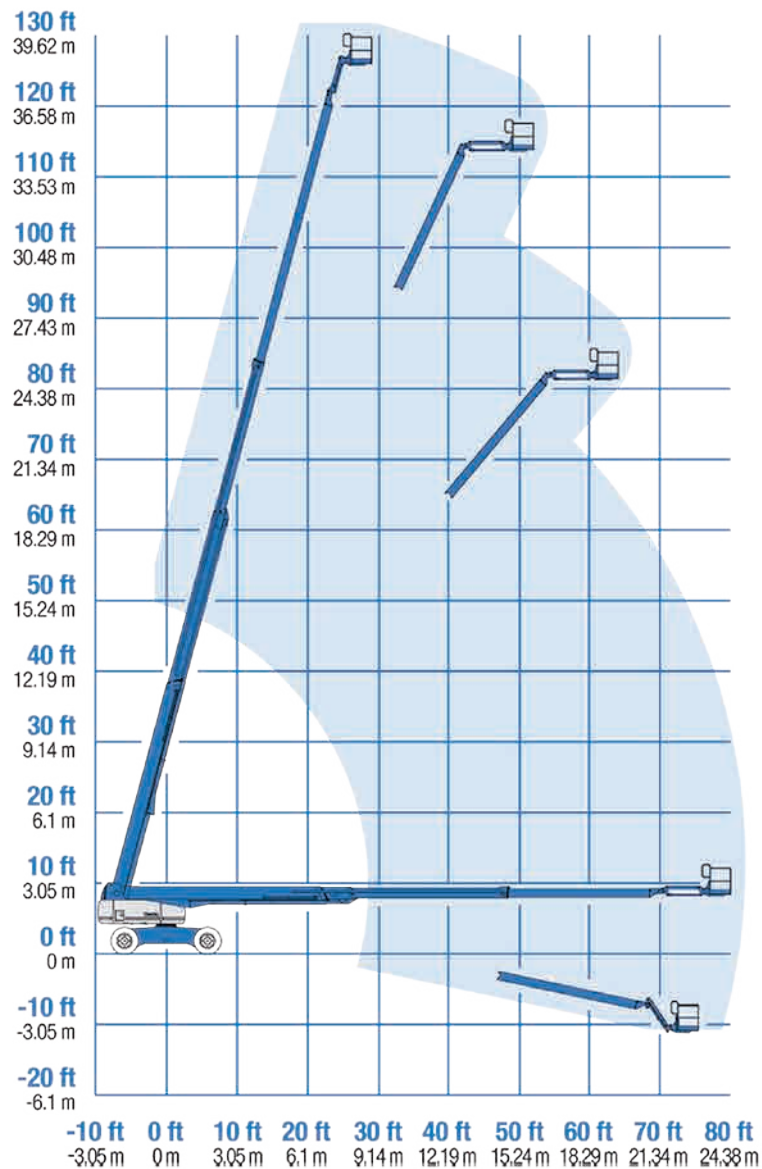

PODNOŚNIK KOSZOWY GENIE S-125
 udźwig 227kg wysokość robocza 40m

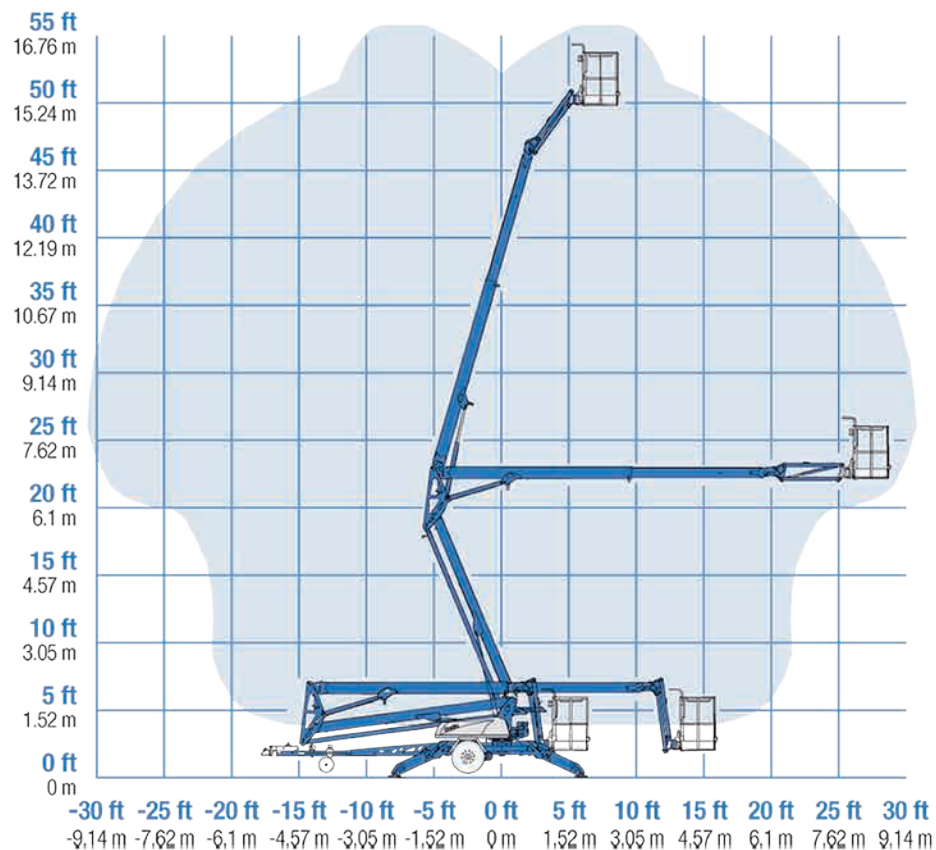
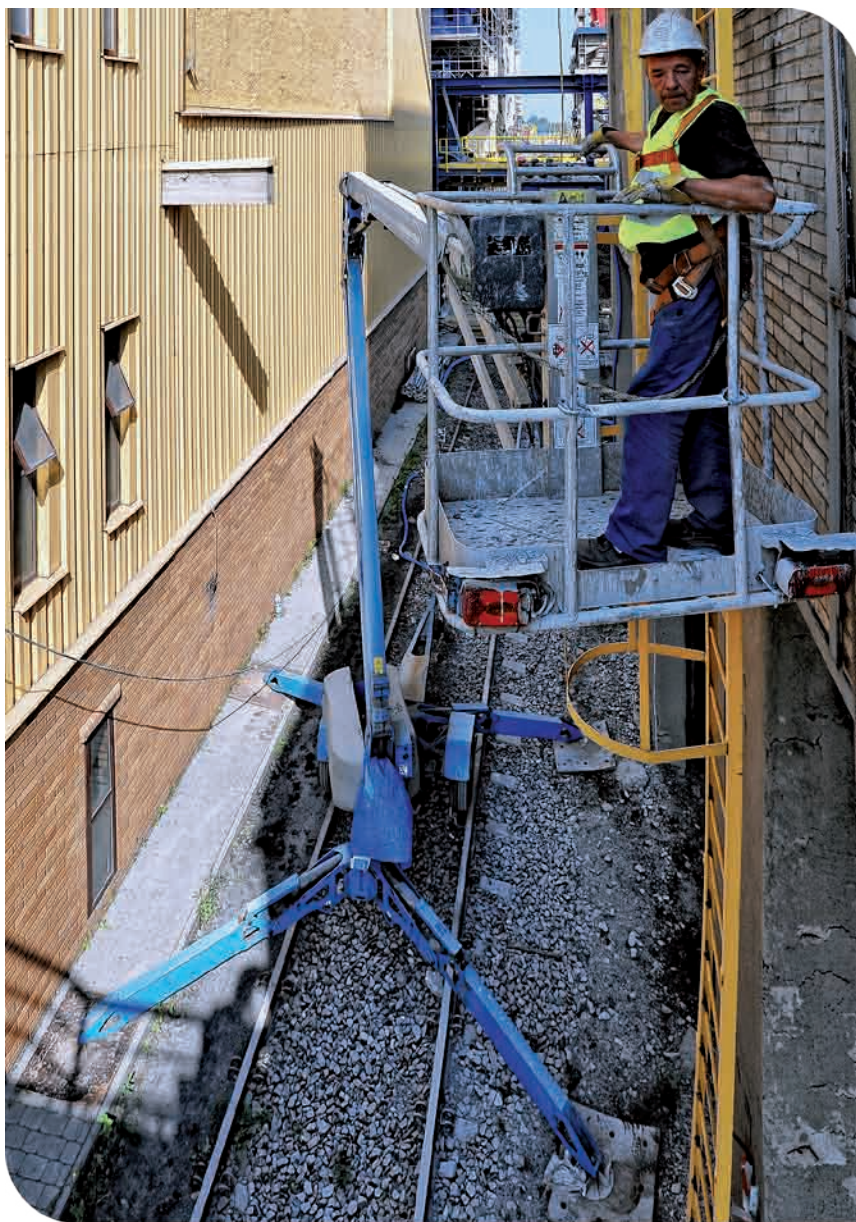

PODNOŚNIK KOSZOWY TZ50
 udźwig 200kg wysokość robocza 17m

TZ50



**Mostostal Puławy S.A.,
ul. Budowlanych 5,
24-110 Puławy-Azoty
Tel. +48 81 473 12 40, 473 12 41
Fax +48 81 473 12 44
www.mostostal-pulawy.com.pl
e-mail: info@mostostal-pulawy.com.pl**

**Biuro Techniczne w Niemczech
Grünstr. 145
40 667 Meerbusch
Tel. +49 2132 759576
Fax +49 2132 759578
e-mail: mail@mostostal-pulawy.de**